

Inch Series Hexagon Keys

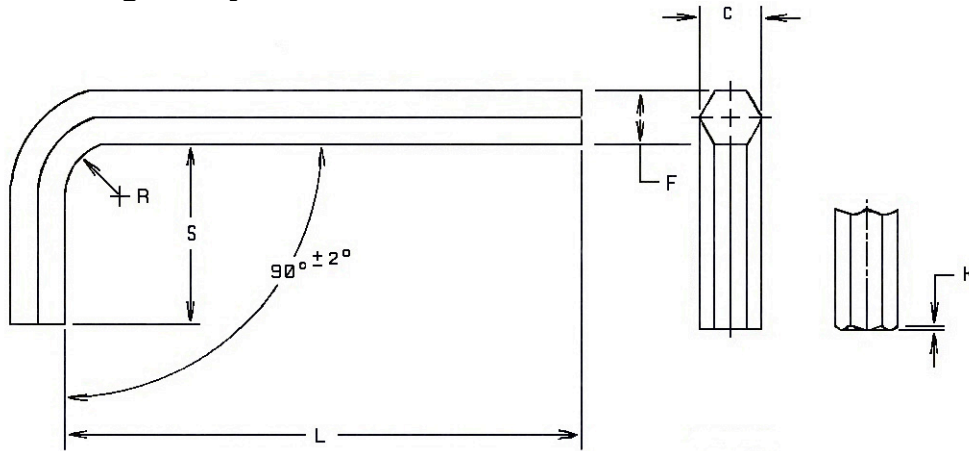

Nominal Key Size	F Hex Width Across Flats		C Hex Width Across Corners		S Length Of Short Arm		L Length of Long Arm Short Series		L Length of Long Arm Long Series		R Radius of Bend Min.	K Chamfer Max.
	Max.	Min.	Max.	Min.	Max.	Min.	Max.	Min.	Max.	Min.		
0.028	0.0280	0.0275	0.0314	0.0300	0.312	0.125	1.312	1.125	2.688	2.500	0.062	0.003
0.035	0.0350	0.0345	0.0393	0.0378	0.438	0.250	1.312	1.125	2.766	2.578	0.062	0.004
0.050	0.0500	0.0490	0.0560	0.0540	0.625	0.438	1.750	1.562	2.938	2.750	0.062	0.006
1/16	0.0625	0.0615	0.0701	0.0680	0.656	0.469	1.844	1.656	3.094	2.906	0.062	0.008
5/64	0.0781	0.0771	0.0880	0.0859	0.703	0.516	1.969	1.781	3.281	3.094	0.078	0.008
3/32	0.0937	0.0927	0.1058	0.1035	0.750	0.562	2.094	1.906	3.469	3.281	0.094	0.009
7/64	0.1094	0.1079	0.1238	0.1210	0.797	0.609	2.219	2.031	3.656	3.469	0.109	0.014
1/8	0.1250	0.1235	0.1418	0.1390	0.844	0.656	2.344	2.156	3.844	3.656	0.125	0.015
9/64	0.1406	0.1391	0.1593	0.1566	0.891	0.703	2.469	2.281	4.031	3.844	0.141	0.016
5/32	0.1562	0.1547	0.1774	0.1745	0.938	0.750	2.594	2.406	4.219	4.031	0.156	0.016
3/16	0.1875	0.1860	0.2135	0.2105	1.031	0.844	2.844	2.656	4.594	4.406	0.188	0.022
7/32	0.2187	0.2172	0.2490	0.2460	1.125	0.938	3.094	2.906	4.969	4.781	0.219	0.024
1/4	0.2500	0.2485	0.2845	0.2815	1.219	1.031	3.344	3.156	5.344	5.156	0.250	0.030
5/16	0.3125	0.3110	0.3570	0.3531	1.344	1.156	3.844	3.656	6.094	5.906	0.312	0.032
3/8	0.3750	0.3735	0.4300	0.4238	1.469	1.281	4.344	4.156	6.844	6.656	0.375	0.044
7/16	0.4375	0.4355	0.5018	0.4944	1.594	1.406	4.844	4.656	7.594	7.406	0.438	0.047
1/2	0.5000	0.4975	0.5735	0.5650	1.719	1.531	5.344	5.156	8.344	8.156	0.500	0.050
9/16	0.5625	0.5600	0.6452	0.6356	1.844	1.656	5.844	5.656	9.094	8.906	0.562	0.053
5/8	0.6250	0.6225	0.7169	0.7080	1.969	1.781	6.344	6.156	9.844	9.656	0.625	0.055
3/4	0.7500	0.7470	0.8603	0.8512	2.219	2.031	7.344	7.156	11.344	11.156	0.750	0.070
7/8	0.8750	0.8720	1.0036	0.9931	2.469	2.281	8.344	8.156	12.844	12.656	0.875	0.076
1	1.0000	0.9970	1.1470	1.1350	2.719	2.531	9.344	9.156	14.344	14.156	1.000	0.081
1 1/4	1.2500	1.2430	---	---	3.250	2.750	11.500	11.000	---	---	1.250	0.092
1 1/2	1.5000	1.4930	---	---	3.750	3.250	13.500	13.000	---	---	1.500	0.104

Applicable Specifications: ASME B18.3.

Hardness: R_C 45-53.

Inch Series Hexagon Keys (continued)

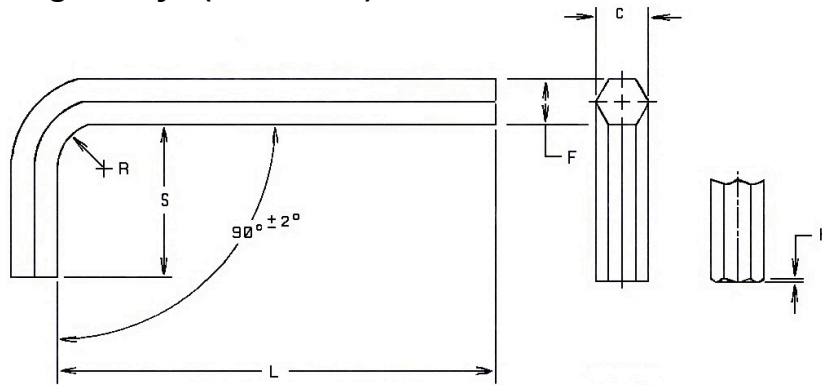

Mechanical Properties

Nominal Hex Key Size	Torsional Shear Average (inch-pounds)	Torque Rating (inch-pounds)
0.028	1.1	0.9
0.035	2.3	1.8
0.050	6.5	5.3
1/16	11.9	10.3
5/64	25.0	20.0
3/32	43.0	35.0
7/64	68.0	55.0
1/8	98.0	82.0
9/64	146	118
5/32	195	160
3/16	342	278
7/32	535	440
1/4	770	655
5/16	1600	1275
3/8	2500	2200
7/16	4500	3500
1/2	6300	5200
9/16	8750	6500
5/8	12000	9000
3/4	19500	15500
7/8	29000	24600
1	43500	28800

Inch Series Hexagon Keys (continued)

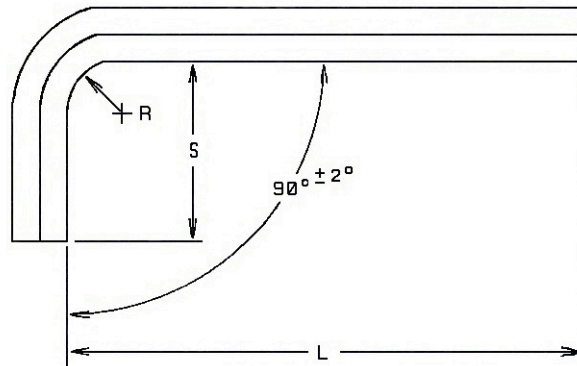

Hex Key/Socket Screw Product Application

Nominal Hex Key Size	Socket Head Cap Screws	Flat Head Socket Cap Screws	Button Head Socket Cap Screws	Socket Shoulder Screws	Socket Set Screws	Pressure Plugs
Nominal Screw Sizes						
0.028	---	---	---	---	#0	---
0.035	---	#0	#0	---	#1 #2	---
0.050	#0	#1 #2	#1 #2	---	#3 #4	---
1/16	#1	#3 #4	#3 #4	---	#5 #6	---
5/64	#2 #3	#5 #6	#5 #6	---	#8	---
3/32	#4 #5	#8	#8	---	#10	---
7/64	#6	---	---	---	---	---
1/8	---	#10	#10	1/4	1/4	---
9/64	#8	---	---	---	---	---
5/32	#10	1/4	1/4	5/16	5/16	1/16
3/16	1/4	5/16	5/16	3/8	3/8	1/8
7/32	---	3/8	3/8	---	7/16	---
1/4	5/16	7/16	---	1/2	1/2	1/4
5/16	3/8	1/2	1/2	5/8	5/8	3/8
3/8	7/16 1/2	5/8	5/8	3/4	3/4	1/2
7/16	---	---	---	---	---	---
1/2	5/8	3/4	---	1	7/8	---
9/16	---	7/8	---	---	1 1 1/8	3/4
5/8	3/4	1	---	1 1/4	1 1/4 1 3/8	1
3/4	7/8 1	1 1/8	---	---	1 1/2	1 1/4
7/8	1 1/8 1 1/4	1 1/4 1 3/8	---	1 1/2	---	---
1	1 3/8 1 1/2	1 1/2	---	1 3/4	1 3/4 2	1 1/2 2